



# MANUAL

for the

**BMW MOTOR CYCLES**

**Models R 51/66 and R 61/71**



## MANUAL

for the

**BMW Two-cylinder Motor Cycles**

**R 51** (500 ccm) Sport Model

**R 66** (600 ccm) Side Car Model

**R 61** (600 ccm) Touring Model

**R 71** (750 ccm) Touring Model

---

BAYERISCHE MOTOREN WERKE A.G. MUNICH 13

If you want your machine to operate reliably and smoothly,  
always have

**Original BMW Spare Parts** fitted!

The trade mark etched into every spare part is a guarantee  
for the same excellence of fit and quality as that of the  
original part.

Our trade mark BMW enables you to uphold the value  
of your machine!

## CONTENTS

Preface . . . . .	4
Controls . . . . .	5
Short Running Instructions . . . . .	6
Running-in Period . . . . .	10
Changing the Tyres . . . . .	12
Cleaning the Carburettors . . . . .	15
Care of the Machine . . . . .	17
1. Lubrication . . . . .	17
2. Maintenance . . . . .	18
3. Cleaning . . . . .	24
Description of:	
Engine . . . . .	25
Carburettor . . . . .	29
Clutch . . . . .	33
Transmission Gear . . . . .	34
Frame . . . . .	35
R 51 SS . . . . .	39
Technical Data . . . . .	40
Index . . . . .	41
Lubrication Chart . . . . .	45

## PREFACE

This Manual contains concise and practical instructions for operating our Models R 51/66 and R 61/71.

Model R 51 is a 500 ccm and R 66 a 600 ccm machine, both with overhead valves, whilst R 61 is fitted with a 600 ccm and R 71 with a 750 ccm engine, these two being equipped with side valves.

Special attention is called to the superlative road characteristics obtained by the employment of telescopic springing for both front and rear wheels.

The similarity of the engines and springing of the frames of the above-mentioned four models makes it possible to treat all four in one and the same booklet, this at the same time affording an interesting summary of the entire BMW constructional programme in the heavy class.

The arrangement of this manual is such that every user can easily find what he requires for his particular machine. All owners of a BMW cycle, and especially beginners, are urgently recommended to read this manual carefully before starting on their first ride.

In case of unsatisfactory operation and if the cause cannot be located with certainty, it is recommended to communicate with the next BMW Agent or Service Station, or with the Makers direct; model, frame and engine number should be stated in the latter case. Beginners are urgently cautioned against undertaking any experimental tinkering on their own account.

The contents of this booklet are not binding for the extent of delivery, this being determined by the contract of sale only.

Munich, March 1938.

**Bayerische Motoren Werke  
Aktiengesellschaft**

Codes: ABC 5th and 6th Edition and Rudolf Mosse.  
Telegraphic Address: Bayernmotor. - Telephone: 33737.  
Address for goods: München Milbertshofen.

## Controls

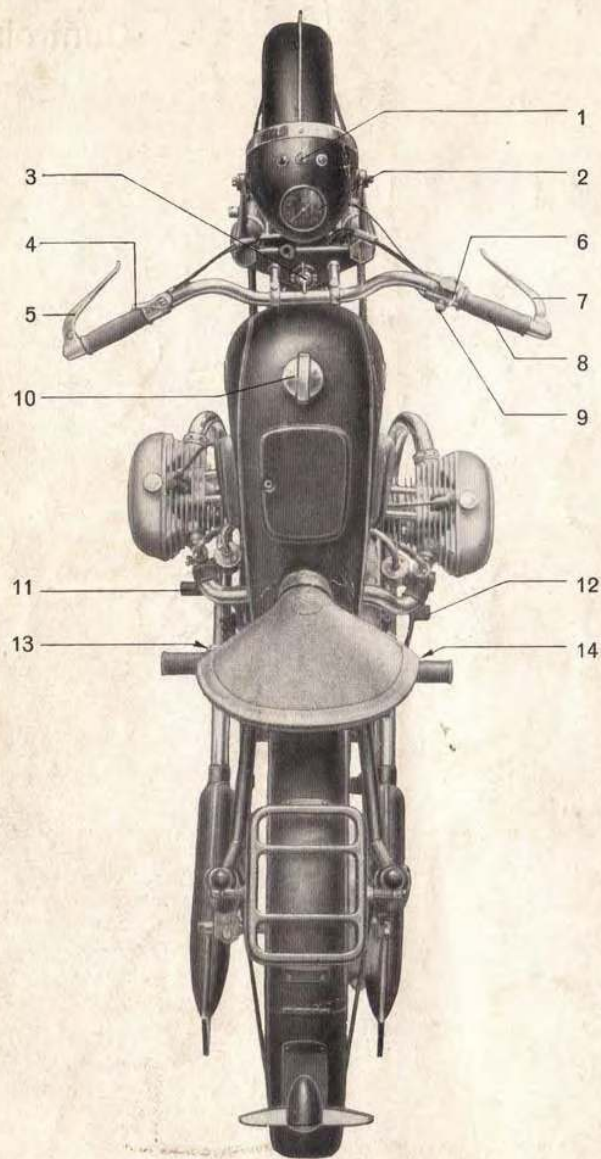

## Controls:

1. **Hole for ignition key:**  
When key is inserted the control lamp flashes up and the engine can be started.  
By turning the key to the left the stop lamp is switched on and by turning it to the right the double filament bulb.
2. **Speedometer.**
3. **Steering damper:**  
On bad roads and when riding at high speed tighten up the damper screw, when riding at low speed slacken screw.
4. **Ignition lever:**  
Always adjust this lever in accordance with the engine speed. When starting, when engine is running slowly, and when the engine knocks (hill climbing), retard the ignition. The higher the engine speed, the more should ignition be advanced.
5. **Clutch lever:**  
Pulling this lever interrupts the power transmission from engine to gear box.
6. **Dimming switch:**  
This switch controls the distance light and dimming light of the two-filament lamp.
7. **Hand brake lever:**  
This lever actuates the front wheel brake. This brake should be used only in conjunction with the foot brake.
8. **Rotary grip gas control:**  
Turning this grip to the left (towards the rider) opens the gas slide valve and turning it to the right (away from the rider) shuts off gas. During the running-in period the opening of the gas valve is limited by stops. Therefore never try to force the grip beyond the point where resistance to motion is felt.
9. **Push button for horn.**
10. **Fuel filling hole:**  
The fuel tank holds about 14 litres ( $3\frac{1}{8}$  gallon).
11. **Pedal gear control:**  
This lever returns automatically to its initial position after each actuation.
12. **Foot brake lever:**  
The foot brake acts on the rear wheel. When running downhill, utilize the braking power of the engine by changing to a low gear.
13. **Kick starter:**  
Before actuating the kick starter, see to it that gear is in neutral position and ignition is retarded.
14. **Hand gear lever:**  
This lever serves to quickly and surely find the neutral gear position (lever then slants slightly to the rear).

## Short Running Instructions

### Before Starting:

Replenish fuel . . . . .

Check oil level . . . . .

Check tyre pressure . . . . .

### Starting:

Push ignition key in . . . . .

Open fuel cock . . . . .

Adjust ignition lever and gas grip . . . . .

Operate kick starter . . . . .

Let engine run idle until warm . . . . .

Use only petrol-benzole mixture (B. P. Ethyl, Esso Ethyl, Esso Benzole Mixture, etc.) for: R 51, R 66 and R 61.

Commercial petrol for R 71.

Capacity of tank: about  $3\frac{1}{8}$  gallon.

For the first 1300 miles the addition of a good top lubricant is recommended.

The oil should reach to the upper mark on the oil gauge rod.  
On no account fill in more oil.

The oil gauge rod should be pushed in but not screwed in.

**In summer:** Mobile Oil BB;

**in winter:** Mobile Oil Arctic.

Renew oil every 1300 miles (see also „Running-in Period“).

	Front	Rear
Solo	20	20 lbs. p. sq. in.
With companion	20	27 lbs. p. sq. in.
Side car machine	27	37 lbs. p. sq. in.

Red lamp flashes up.

When the engine is not running, the ignition should never remain switched on for any length of time.

This cock has three positions: Z = closed, A = open, R = reserve.

When engine is **cold**, retard ignition, open gas slide valve slightly and depress tickler of carburettor.

When engine is **warm**, retard ignition, open gas valve slightly, but **do not depress tickler**.

Depress with short and powerful strokes.

This is very important, as otherwise excessive wear of cylinders will result. Engine should run idle with medium r. p. m., never with valve fully open.

## On the Road:

Declutching . . . . .

Gear control . . . . .

**Start in 1st gear; in congested traffic, employ 2nd or 3rd gear, on the open road top gear.**

Adjust ignition . . . . .

Letting in the clutch . . . . .

Maximum speeds . . . . .

## Stopping:

**Shut off gas by closing slide valve.**

**As soon as speed sufficiently reduced, declutch and put on brake gradually.**

**Move hand gear lever to neutral (lever slanting slightly to rear).**

**Stop engine by removing ignition key.  
Close fuel cock (position „Z”).**

Pull lever on left side of handle bar.

1st gear: depress pedal.

1st to 2nd to 3rd to top gear: each time pull up pedal, at same time reducing gas.

Top to 3rd to 2nd to 1st: each time depress pedal, gas valve slightly open.

Neutral: to change to neutral employ hand gear lever.

The higher the r. p. m. , the more the ignition should be advanced.

When engine is running slowly and when hill climbing, retard ignition.

Release clutch lever slowly and at same time slightly open gas valve.

The following should never be exceeded:

	1st	2nd	3rd	Top gear
0 to 650 miles:	10	16	25	37 m. p. h.
650 to 1300 miles:	13	25	37	53 m. p. h.

## The Running-in Period . . .

is of the very greatest importance for the life and reliable operation of the engine. It is therefore urgently recommended to pay special attention to the following instructions:

### Admissible maximum speeds:

0—650 miles		650—1300 miles	
1st gear	10 m. p. h.	1st gear	13 m. p. h.
2nd gear	16 m. p. h.	2nd gear	25 m. p. h.
3rd gear	25 m. p. h.	3rd gear	37 m. p. h.
top gear	37 m. p. h.	top gear	53 m. p. h.

(These data refer to solo riding on level roads.)

In order to have a certain guarantee that these speeds are not exceeded, a sealed stop is fitted on the carburettor at the makers works. This stop will be **shortened after the first 650 miles** and **removed after another 650 miles** by the next BMW agent.

**Beware of unauthorized interference with this sealed stop or with the seal on the speedometer!**

The above does not mean that the speeds mentioned must be maintained at all costs or that the gas valve must always be opened as far as the stop. On the contrary, it is best to run the machine in by riding a short distance (about 550 yards) with the maximum admissible speed and then shutting off gas and allowing the machine to roll and to keep on repeating this process.

**After the first 1300 miles it is also recommended not to ride long distances with the maximum speed, but to gradually increase the average speed until the machine has done 2000 miles.**

### Lubrication:

During the running-in period special attention must be paid to lubrication. **After every 300 miles** the oil in the crank case must be carefully drained off at the drain screw of the oil well, the engine rinsed with scavenging oil and **fresh oil filled in up to the upper mark of the oil gauge rod. The oil in the gear box and in the rear axle casing** must be entirely drained off after the running-in period and fresh oil filled in until the oil level reaches to the screw threading of the filling-in hole.

### Lubricants:

	Summer:	Winter:
Engine:	Mobile Oil BB	Arctic
Cylinder head R 51 and R 66:	Mobile Oil BB	BB
Transmission gear:	Mobile Oil BB	BB
Rear axle casing:	EP	EP
Frame:	Gargoyle Mobile Grease Nr. 4	

After the running-in period the following speeds should not be exceeded:

	1st	2nd	3rd	Top gear
R 51	28	47	63	88 m. p. h.
with side car gear	22	37	53	70 m. p. h.
R 66	35	53	72	95 m. p. h.
with side car gear	28	47	63	78 m. p. h.
R 61	16	35	50	72 m. p. h.
with side car gear	13	28	44	60 m. p. h.
R 71	22	40	60	78 m. p. h.
with side car gear	16	35	50	65 m. p. h.

### Caution:

The above speeds are not the maximum attainable speeds; they represent the miles per hour equivalent to the admissible maximum r. p. m. of the engine. To exceed these speeds (for instance, when running downhill) would therefore cause an inadmissible overrevving of the engine.

## Changing the Tyres

### Disassembling the front wheel:

1. Slacken set screw of crutch at mud guard and prop wheel on crutch.
2. Screw in adjusting screw (4) as far as it will go and set it so that its slot corresponds with the slit in the throughgoing screw.
3. Lift brake lever (6) and unhook wire cable (3) together with holder bolt (7).
4. Slacken clamp screw on left side of fork and screw out axle (1). (Left-hand thread)
5. Remove front wheel together with brake cheek holder.
6. When again assembling, take care that nose (9) engages with guide in fork.
7. Before tightening up the clamping screw on left side of fork, spring the fork several times well up and down.



Fig. 1  
Disassembly of the front wheel.

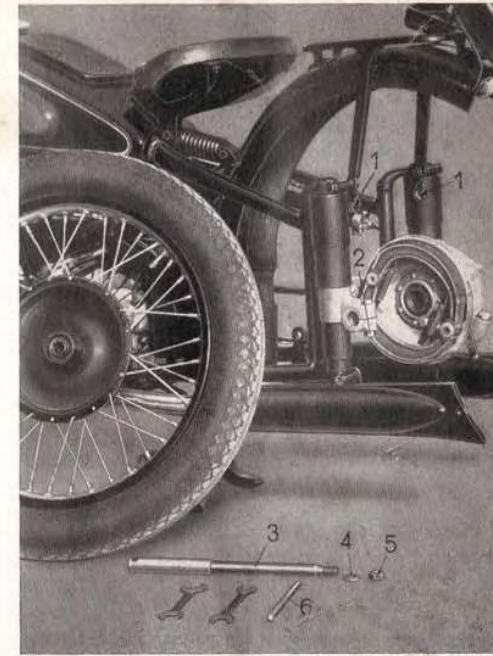

Fig. 2. Disassembly of the rear wheel.

### Disassembling the rear wheel:

1. Prop wheel on crutch.
2. Slacken set screw of mud guard stay and lift up end of guard.
3. Slacken axle nut (5) on drive side and remove together with washer (4).
4. Slacken clamp screw (2) and screw out axle (3) with the help of bolt (6).
5. Remove wheel.
6. When again pushing in axle (3), turn it so that it cannot jam, then tighten up axle and fix with lock nut (4, 5). Spring machine up and down several times and finally tighten up clamp screw (2).

**Keep all parts of axle clean; before assembly, clean with rag and grease slightly.**



## Tyres:

The wheels are fitted with safety well rims which differ from the ordinary rims in that a cross web is pressed in opposite the air valve. By this means springing out of the tyre when suddenly deflated is prevented.

### Avoid using force when removing or mounting a wired tyre.

**Removing the tyre:** Deflate tyre and press cover all round rim out of its seat; unscrew valve nut and push valve into tyre. Push tyre flange at valve into the well and on opposite side lift over side of rim. In this way the tyre flange can be lifted bit by bit over the rim side, after which the inner tube can be removed. The second tyre flange may now be lifted out of the rim in the same way.

**Repairing the inner tube:** First inflate the damaged tube in order to find the fault, which can be located by the hiss of the outgoing air. Another method is to dip the inflated tyre in a basin filled with water, when the fault can be easily located by the air bubbles rising in the water.

Having found the fault, clean the place with glass paper or with the rough surface of the talcum tin, apply rubber solution and let it dry about three minutes. Now strip the fabric from one of the rubber patches contained in the repair outfit and press the patch tightly on the faulty place of the tube. Before replacing the tube, the tyre cover must be carefully examined and the nail or other object which caused the damage removed.

**Mounting the tyre:** Lay wheel flat on ground. Place tyre flange in well of rim at valve hole and then, beginning on the opposite side of the rim, lift tyre flange bit by bit over side of rim. (Caution: Never employ force!). Sprinkle with talcum powder and insert the slightly inflated inner tube, pushing the valve through the valve hole and screwing the valve nut on a few turns. When pushing the second tyre flange into its place, push the valve in as far as the nut, so that the flange can lie properly in the well and the opposite side be lifted over the rim. Now inflate tyre and check whether the circumference line of the tyre is everywhere at the same distance from the rim. Tighten up valve nut and check tyre pressure, which should be as follows:

	Front	Rear
Solo	20	20 lbs. p. sq. in.
With companion	20	27 lbs. p. sq. in.
Side car machine (3 persons)	27	37 lbs. p. sq. in.

**Always maintain tyres at correct pressure, which will greatly help to lengthen their life.**

## Cleaning the Carburettors:

If the engine output suddenly decreases and the engine no longer comes up to the r. p. m. corresponding to the position of the gas valve, the fault is generally to be sought in insufficient fuel feed or a clogged jet.

In such case unscrew the water trap at the fuel cock and also clean the strainer contained in same. (The fuel cock must of course be previously closed.) After this unscrew the fuel pipes at the carburettors and check whether the fuel flows unhindered by momentarily opening the cock. If the fuel flow is in order, but the faulty operation of engine still continues, the carburettors must be disassembled and cleaned.

### R 51/61/66:

1. Close fuel cock and unscrew feed pipe (1).
2. Slacken holder bolt (9) and remove float chamber (3).
3. Screw off cover (8) of float chamber after slackening clamp screw (6), remove float (4) and thoroughly rinse float chamber with petrol.

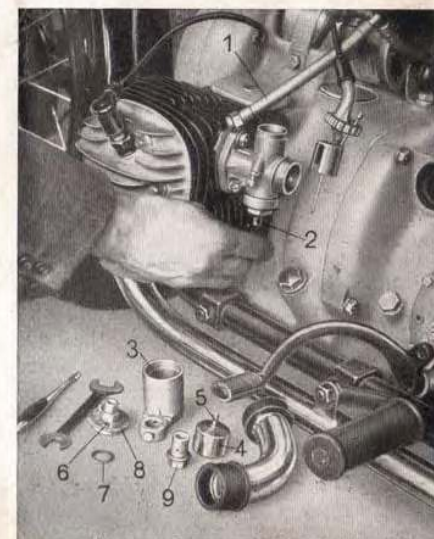

Fig. 3. Carburettor R 51/61/66.

4. Screw jet (2) out and suck at it; if clogged, clean with a horse hair or the like. Never use a hard pointed object for this purpose, which would damage and therefore change the fine jet aperture.
5. When again assembling, see to it that the float needle (5) points upwards and that a gasket (7) is placed both above and below the bore for the fixing bolt (9).

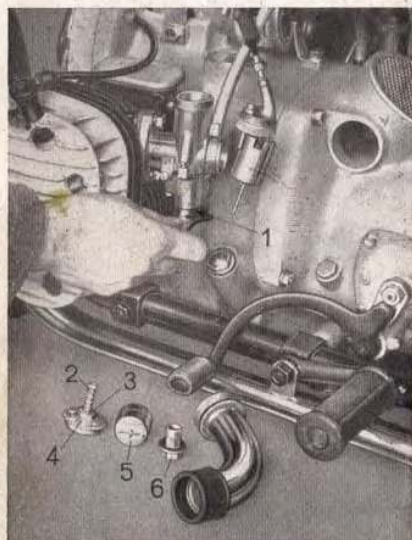

Fig. 4. Carburettor R 71.

#### R 71:

In this carburettor the float chamber is not removable as in the above-described type. Jet (1) becomes accessible after unscrewing plug (6). The strainer of this bolt must be cleaned; after float (5) has been taken out, the float chamber can be cleaned by rinsing with petrol. The feed pipe is pushed over a ribbed connecting nipple (2) on cover (4). The latter has a hexagonal top (3) so that it can be screwed tight on the float chamber.

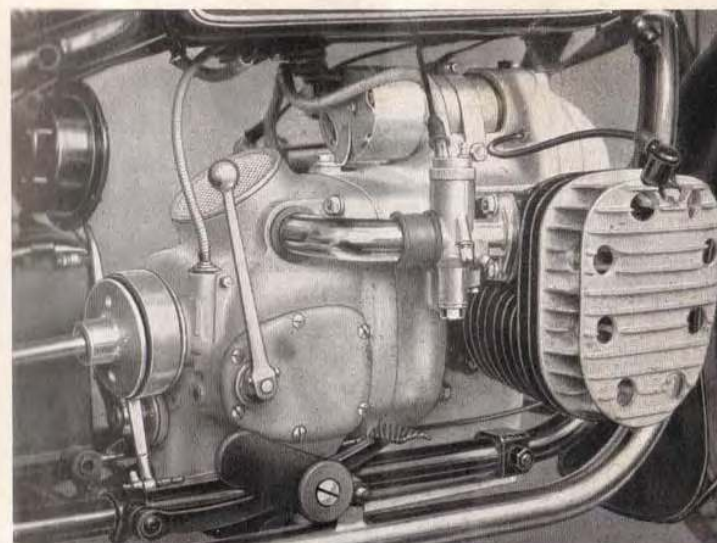

Fig. 5. Engine of R 71.

## Care of the Machine

The most important factors in the care of the machine are:

1. Lubrication.
2. Maintenance.
3. Cleaning.

### 1. Lubrication:

Lubrication of engine, gears and frame plays a very important part in the care of the machine and it is in the interests of every owner of a BMW cycle to lubricate his machine at regular intervals according to the „Lubrication Chart“ contained at the end of this Manual. Further, special attention should be paid to the instructions for the running-in period given on page 10.

The oil level in the crankcase should be checked after every 250 miles and, if necessary, oil filled in up to the prescribed level. The oil level is checked with the help of the oil gauge dip rod provided with a hexagonal head and kept on the left side of the engine. The oil should reach to the upper mark of this rod. Care must be taken **not to fill in more than this**, and also **never to let the oil level sink below the lower mark on the rod**. When checking the oil

level, do not screw the plug in, but simply push the rod in as far as the threads of the plug.

When competing in races or reliability runs etc. the temporary employment of special racing oils is permissible. On reliability runs castor oil should in general not be used for the machines R 51 and R 66, or at most only during the final run. But in no case may castor oil be mixed with other oils.

## 2. Maintenance:

To permanently maintain the reliable operation and efficiency of the machine, proper care of engine and frame is indispensable.

### Engine:

Never let the engine run idle at high speed and never try to force a hill with top gear.

Therefore always change to the next lower gear before the engine speed falls too low; operation, even for long periods, on the lower gears is in no way harmful either to engine or transmission. From time to time tighten up the fastening bolts of the engine and the cylinder head screws; also, after somewhat longer periods, check the valve clearance. When the engine is cold, the valve clearance should be about 0.1 mm (.004") or about the thickness of ordinary letter paper.

### Adjustment of valve clearance:

R 51/66:

*.004" COLD, BOTH VALVES.*

1. Place a dish or other container under the cylinder head to catch the oil.

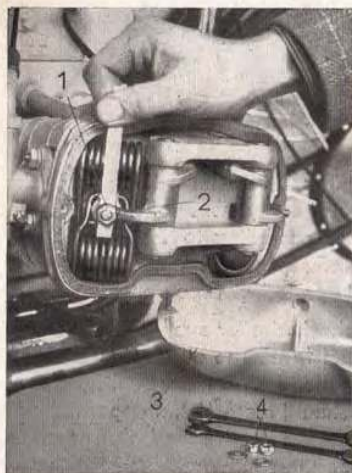

ROCKER ARM.  
No. 2541-05-071-1

Fig. 6. Cylinder head R 66 (R 55).

2. Unscrew fastening nuts (4) of cover (3) and remove cover.

3. Turn engine until the valve to be checked is closed and then check clearance with a piece of paper .004" thick. This must be done **when the engine is cold.**

4. If clearance is faulty, slacken lock nut (1) and adjust to correct gap by screwing the set screw (2) in or out.

5. Hold set screw in position with spanner and tighten up lock nut.

6. After adjustment of both valves, screw cover on again and fill in about  $\frac{1}{3}$  pint of Gargoyle Mobil Oil BB.

### R 61/71:

1. Remove holder screw (3) with a screwdriver and lift off cover (4) together with gasket (5).

2. Turn engine until the valve to be checked closes.

3. Check clearance with paper strip .004" thick **when engine is cold.**

4. If clearance is faulty, hold tappet screw (2) with spanner (6) and slacken lock nut (7) of tappet screw with the help of another spanner.

5. Adjust to correct clearance with tappet screw (2) — the paper strip must go easily between valve and tappet screw — and again tighten up lock nut (7).

6. Close valve chamber by again screwing on cover (4).

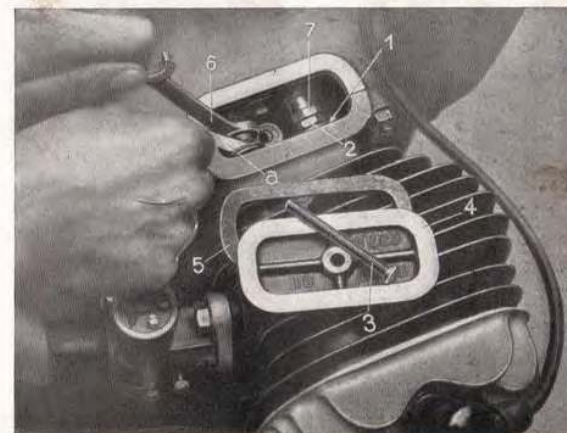

Fig. 7. Adjustment of valves in R 61 (R 71).

### Care of ignition system:

The condition of the ignition system is of primary importance for the reliable operation of the engine. Battery, sparking plugs, contact breaker and dynamo must therefore be periodically inspected.

### Battery:

The battery is delivered **uncharged** and **without acid**. Before using the machine, the battery must therefore be removed and filled with chemically pure acid (battery acid). After five or six hours acid is again added until it reaches to about  $\frac{1}{8}$  inch over the plates. The battery should now be charged with a current of maximum 1 ampere until all cells gas or boil thoroughly and the tension has increased to about 2,6 volts (measured during charging).

At regular intervals (about every four to six weeks) the level of the acid should be checked and, if necessary, the cells filled up to the proper level by adding **distilled water**. The top of the cells should always be kept clean and dry.

If the machine remains unused for more than six weeks, the battery must be charged with the help of a separate current supply.

### Sparking plugs:

The sparking plugs are continuously subjected to a high stress and therefore slowly deteriorate. Every 3000 miles the sparking gap should be checked and, if too great, the side electrode must be tapped in with light blows of a mallet until the gap is again correct (.02").

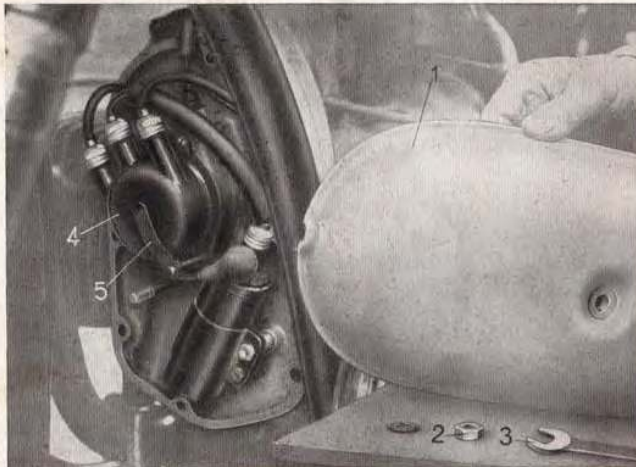

Fig. 8. Ignition system R 61 (R 66 - R 71).

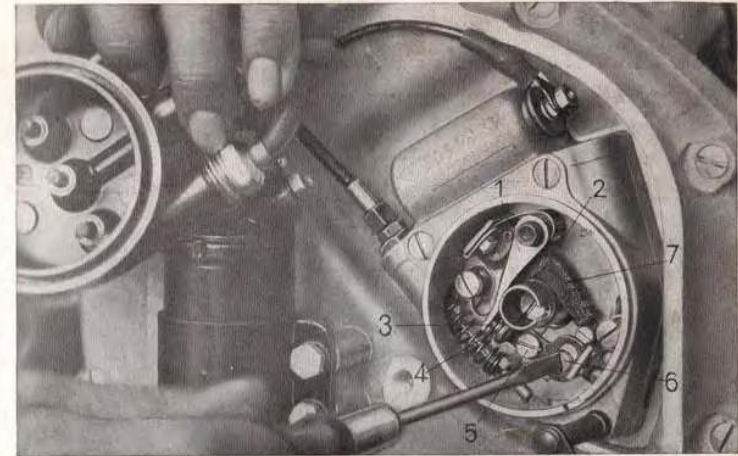

Fig. 9. Contact breaker.

If during the running-in period or during very cold weather the prescribed "Bosch" sparking plug **W 240 T 1** does not operate satisfactorily, a plug with a lower heat coefficient (Bosch W 175 T 1) may be employed.

### Contact breaker:

Approximately **every 3000 miles** the contact breaker points should be inspected. The gap should be .016 to .020" and the contact surfaces clean and smooth. Ignition coil, distributor and contact breaker are arranged under one and the same cover at the front of the engine.

Adjustment of the gap is done as follows:

1. Remove cover (1) after slackening nut or screw (2).
2. Push holder spring (5) aside and remove distributor cover (4).
3. Withdraw distributor runner after slackening grub screw on its hub.
4. Turn engine until contact breaker opens to the full.
5. Adjustment can now be made after slackening holder screw (5) by turning eccentric screw (6); the gap should be .016" to .020".
6. After adjustment the holder screw (5) must be again well tightened up. A few drops of good oil should be applied to lubricating pad (7).

If the contact surfaces are pitted they must be removed and smoothed with the help of a special contact breaker file. Burnt contacts must be renewed at a "Bosch" Service Station.

### Dynamo:

Brushes and commutator of the dynamo must be inspected regularly **every 3000 miles**. See to it that the brushes are clean and do not jam in their guides.

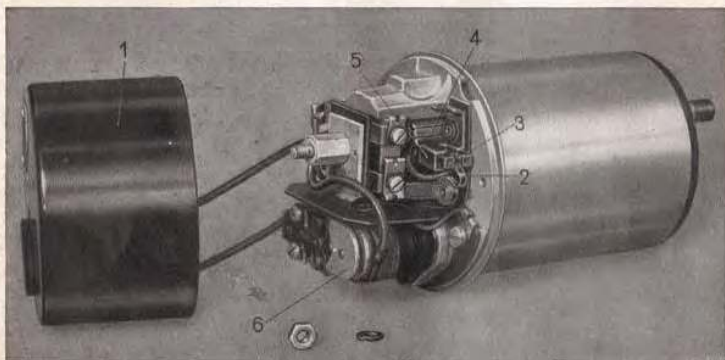

Fig. 10. Dynamo.

After removing cover (1), lift springs (2) which press the brushes (3) on the commutator (4) and then try to shift the brushes to and fro in their guides. If one of the brushes is fouled or sticks, it must be removed and cleaned with a rag dipped in petrol. The brush holder (5) must also be cleaned.

Under no circumstances should the contact surfaces of the brushes be treated with emery paper or with a file. When a brush is worn down, so far that its copper cable abuts against the recess of the guide, it must be replaced by a new brush.

If the commutator is fouled it must be cleaned with a rag.

**Before starting any job on the dynamo the connection between the latter and the battery must be interrupted.**

The automatic regulator (6) of the dynamo is adjusted in the factory before delivery and should on no account be tampered with.

### Brakes:

Front and rear wheel are each equipped with an internally acting brake. The front wheel brake is operated by means of a Bowden cable and lever on the handle bar and the rear brake by means of rods and a pedal.

Since the safety of the rider is in a high degree dependent on the condition of the brakes, they must always be kept in perfect working order.

**Wear of the brake linings must from time to time be compensated by turning the screws provided for this purpose.** In the case of the front wheel this is done by giving the thumb screw in the centre of the brake cover a few turns in an anti-clockwise direction.



Fig. 11. Front wheel brake.

Adjustment of the rear wheel brake is effected by tightening up the thumb screw situated on the connecting rod.

When adjusting the brakes great care must be taken that a **certain amount of play** remains between the beginning of the braking action and the rest position of the brake lever or pedal, as otherwise there is danger of the brakes dragging and heating up and thus becoming prematurely worn.

If after readjustment the braking effect is still insufficient, the linings are worn out and must be renewed.

When running down long hills, use the front and rear brake alternately, so that each brake has time to cool down. It is a matter of course that **on all steep descents the braking power of the engine** in a low gear must be taken to aid.

Always apply the brakes gently, that is to say, exert pressure gradually, since the best braking effect is obtained when the wheel is still rolling and not when it drags.

### Clutch:

The robust single-plate clutch requires no lubrication, but on the other hand proper treatment of the clutch will considerably lengthen its life. Therefore when starting, open the gas valve only slightly and engage the clutch gradually. Sudden and jerky engagement of the clutch in conjunction with high speed of the engine not only causes the clutch lining to wear very rapidly but also greatly stresses all parts of the transmission as well as the tyres.

From time to time the thumb screw on the cable must be adjusted so that there is always a certain amount of play between engagement of the clutch and the rest position of the clutch lever.

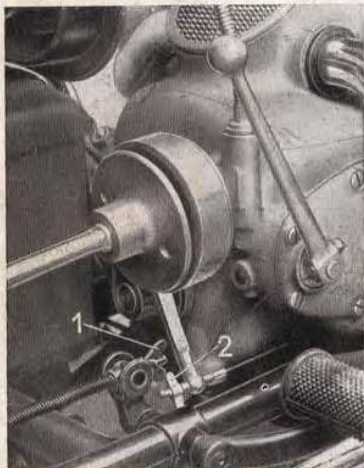

Fig. 12.  
Readjustment of rear brake and clutch.

### 3. Cleaning:

Cleaning the engine, gear box and accessory parts is best done with petrol and a brush, whilst the varnished parts should be washed with a sponge and then rubbed dry with a woolen cloth. If the machine is hosed down, care should be taken that the engine has previously cooled sufficiently. Avoid high pressure when hosing, as any moisture getting into the working parts may lead to faults which are often very difficult to find.

After drying, it is recommended to apply a few drops of oil to the brake links and to the hinges of the rear mud guard in order to prevent rusting.

Chromium plated parts should be kept dry and slightly oiled; if the machine remains unused for any length of time, the chromium plated parts should be coated with acid-free vaseline.

### Engine:

A two-cylinder boxer type engine supplies the motive power. The advantages of this type of engine have been sufficiently proved by the many "Grand Prix" secured by BMW machines, by countless successful Trophy Runs, and by the possession of the absolute speed record.

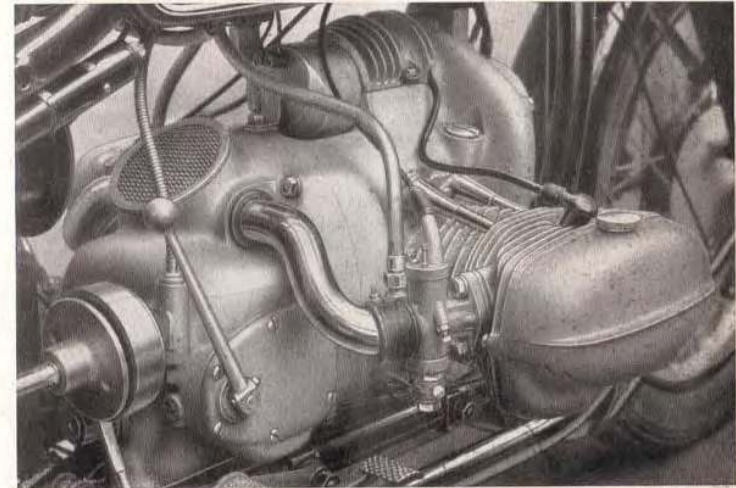

Fig. 13. Engine block R 51.

### Operation:

The engine operates on the four-stroke cycle.

- 1st stroke:** The downgoing piston sucks in the gas mixture through the inlet valve, which is opened by the cam shaft. (Suction stroke).
- 2nd stroke:** The upgoing piston compresses the gas mixture in the cylinder, all valves being closed. (Compression stroke).
- 3rd stroke:** At or near the upper dead centre of the piston the compressed mixture is ignited by the spark at the sparking plug. The expansion due to combustion of the mixture drives the piston outwards. (Working stroke).
- 4th stroke:** The upgoing piston expels the combustion gases through the exhaust valve, which has been opened by the cam shaft. (Exhaust stroke).

These four strokes are repeated in each cylinder in the same order, but at an interval of  $360^\circ$ , so that one working or combustion stroke takes place with each revolution of the crank shaft, as is clearly shown by the following diagram:

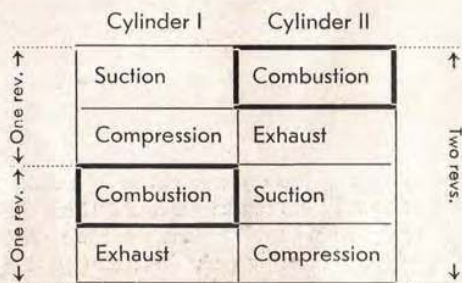

### 1. Crankcase and cylinders:

The crankcase is made of a very strong light metal alloy and is tunnel-shaped. The grey cast iron cylinders are equipped with deep ribs and fitted with removable light metal heads, which, in conjunction with the amply dimensioned ribs, ensure sufficient cooling.

The light metal pistons are fitted with three piston rings and one oil scraper ring. The hardened and ground gudgeon pin is carried in the connecting rod head and locked in position by means of spring rings.

### 2. Crankshaft:

The crankshaft of steel with hardened pins is divided and runs in two sturdy ball bearings. Oil passes through the hollow crank pins and suitable oil ducts to all bearings, the piston, gudgeon pins, etc., so that ample lubrication is ensured. Carefully calculated counterweights and perfectly balanced rotating parts guarantee vibration-free operation.

### 3. Valves:

**The valves of the R 51/66 machine are of the overhead type** and operated by means of rocker arms and enclosed push rods, which latter are in turn actuated by tappets through the medium of the camshaft. The rocker arms in the cylinder head are lubricated by oil contained in the head which does not form a part of the oil circulating system. The removable cover makes adjustment of the valve clearance an easy matter.

**The R 61/71 machines are equipped with side valves** actuated by tappets from the camshaft. The valves are pressed on their seats by means of coil springs. Any oil leaking through the tappet guides is returned into the case through a suitable duct. A removable cover gives access to the tappets and facilitates adjustment of valve clearance.

### 4. Drive of camshaft:

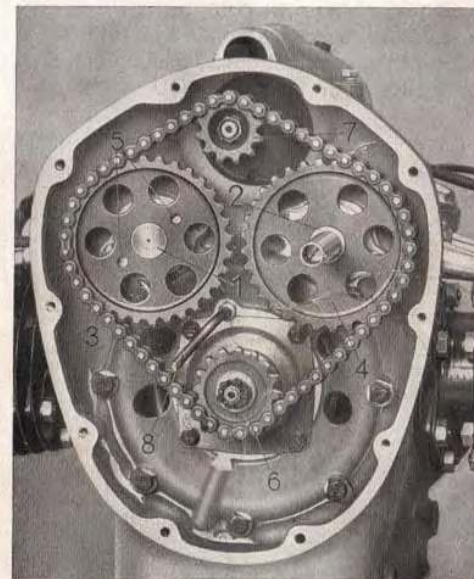

Fig. 14. Chain drive of camshaft R 51.

**R 51 engine:** On each front end of the journal borne camshafts (1 and 2) arranged above the crankshaft, a chain wheel (3 and 4) is keyed. The camshaft (2) is prolonged towards the front and operates the contact breaker. The bores (5) of the camshaft (1) serve to engage the rotary valve for crankcase evacuation. The camshafts (1 and 2) are driven by chain wheel (6) arranged on the crankshaft through the medium of an anti-friction chain, which latter also drives the chain wheel (7) of the dynamo.

The chain is thoroughly lubricated through the oil connection (8).

As can be seen in Fig. 14, the chain wheel of the dynamo is arranged eccentrically, which greatly facilitates tightening up the chain. To do this, remove the cover at the front of the engine and unscrew the hexagonal plug. Through the window thus formed the tension of the chain can be checked. If tightening up is necessary, loosen the fastening screws of the dynamo hood and then tighten chain by turning the dynamo about its axis. After this is done, the **fastening screws of the dynamo must be again well tightened up.**

**R 61/71 engine:** The camshaft is driven by helical gears (2 and 3) from the crankshaft. The pinion (4) of the dynamo engages with the gear wheel (3) of the camshaft. The contact breaker is operated from the front end (5) of the camshaft. Lubrication of the camshaft drive is through oil duct (7). Evacuation of the crankcase is by means of rotary valve (6).

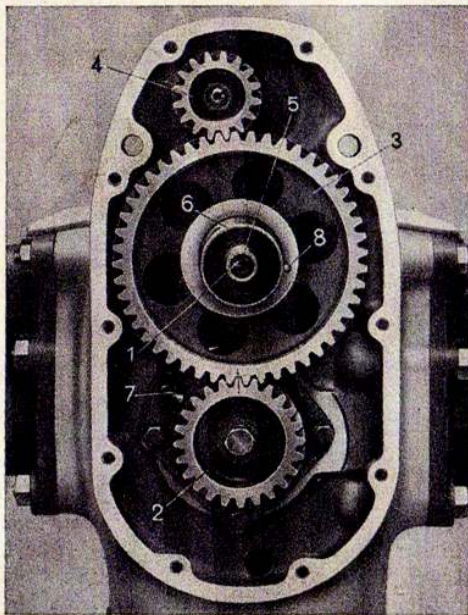

Fig. 15. Spur gear drive of camshaft R 61/66/71.

## 5. Lubrication:

A gear pump built into the crankcase section of the engine ensures ample lubrication even under stressed operation. This pump is driven by worm gear from the camshaft and sucks the oil through a strainer. Pipes conduct the oil to the ball bearings of the crankshaft. From the front bearing a further pressure pipe conducts the oil to the chain (R 51) or to the spur gear drive (R 61/66/71), the front camshaft bearings being also amply lubricated by splash lubrication. The rear camshaft bearings and the roller bearings of the connecting rod are lubricated through suitable ducts by splash oil from the crankshaft. Splash oil also ensures sufficient lubrication of piston and gudgeon pin. Any impurities contained in the oil returning to the sump are retained by a strainer arranged in the crankcase. Excessive pressure in the oil pipes is prevented by a valve in the pump.

## Carburettors:

**"Amal"** carburettors are fitted to the R 51, R 61 and R 66 machines and a **"Graetzin"** carburettor to the R 71 machine. The carburettors of the different machines are essentially alike, so that the following description applies to all types.

The carburettor comprises the following main parts: The **slide valve housing** A in which the cylindrical **gas slide valve** B, the lower part of which is open, is guided; the **jet carrier** F, in which the **main jet insert** O with the main jet P is screwed, a fine bore J being provided as idling jet; and the **float chamber** R.

The Bowden cable from the gas grip control is connected to the top of the slide valve, the lower part of which is cut away on one side, forming a curved opening. A coil spring surrounds the Bowden cable and presses against the upper guide piece on the valve housing and against the valve top, thus urging the slide into its end position. The fuel feed through the main jet P or the main jet insert O is regulated by a jet needle C, tapered at its lower end, which needle is connected to the valve top by means of a small clamp spring engaging in a recess of the needle. This jet needle C projects into the main jet insert O.

If the gas slide valve is only slightly opened, the annular free passage between the jet needle and the main jet insert O is small, the overpressure acting on the main jet is therefore low and the fuel sucked through the main jet consequently also small in quantity. If the slide valve is opened further, the annular passage is enlarged in consequence of the taper form of the needle and the fuel flow also increases. By shifting the clamp spring the needle can be hung higher or lower in the slide valve top, by which means it is possible to vary the composition of the gas mixture.



The amount of fuel flowing to the float chamber R is regulated by the needle valve U on float T; the fuel in the float chamber passes through the channel in the arm of the float chamber into the holes of cap nut Q fastening the float

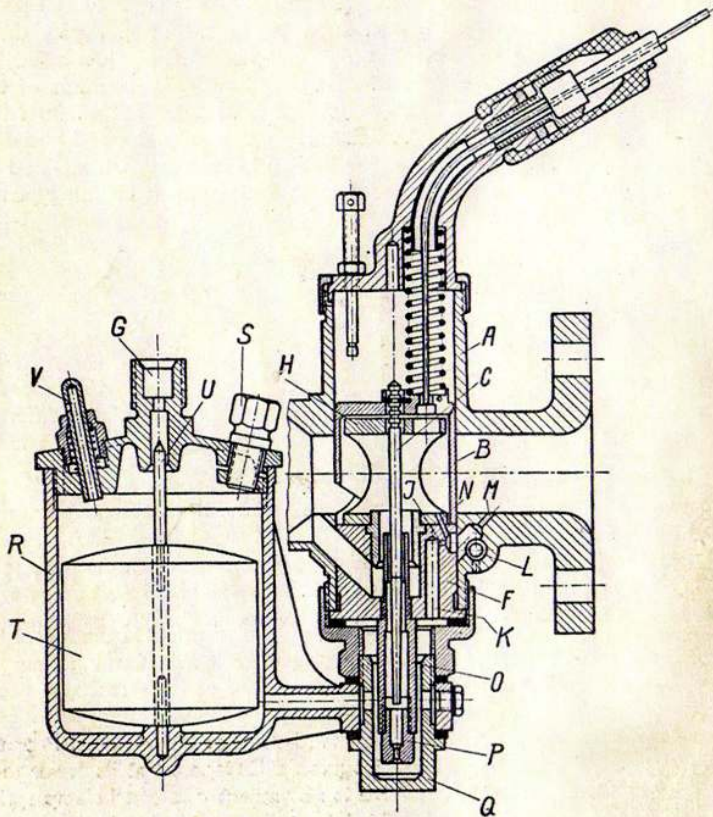

Fig. 16. Carburettor R 51 (R 61 and R 66).

chamber R to the slide valve housing A, whereupon the needle jet and bore K in the jet carrier F fill with fuel. If the slide valve is only slightly open the vacuum caused by the suction stroke of the engine draws air in through the idling air vent L and fuel through the idling jet J, and this fuel-air mixture passes into the combustion chamber of the engine through the idling exit M.

The more slide B is opened, the less will the suction action at the idling exit M be, but a stronger suction action will be obtained at the intermediate jet N, so that the idling mixture flows both through this bore and through exit M.

The gas mixture coming from the idling and intermediate jet systems is supplemented by fuel from the main jet system until the slide valve is about  $\frac{1}{8}$  open. From this point until the valve is about  $\frac{1}{4}$  open the composition of the mixture is dependent on the aperture of the slide valve. When the valve is opened further, from  $\frac{1}{4}$  to  $\frac{3}{4}$  of the slide valve stroke, the mixture is dependent on the position of the needle and after this to full opening of the valve the main jet alone is responsible for the mixture.

The fuel flow G is at the top of the float chamber. A tickler V is arranged in the float chamber cover, which latter is held in position by clamp screw S. When this tickler is depressed the float valve U is held open, by which means it is possible to check the proper flow of fuel. When starting the engine, depression of the tickler causes more fuel to flow to the jets, ensuring a richer mixture and facilitating starting.

#### Air filter:

The two carburettors are provided with a wet air filter common to both. This filter must be removed from time to time and cleaned by washing it with petrol; when dry the filter must be moistened with engine oil and all superfluous oil expelled by swinging the filter at arm's length.

**A fouled or excessively oily filter results in high fuel consumption.**



Fig. 17. Air filter (R 51, 66, 61, 71).

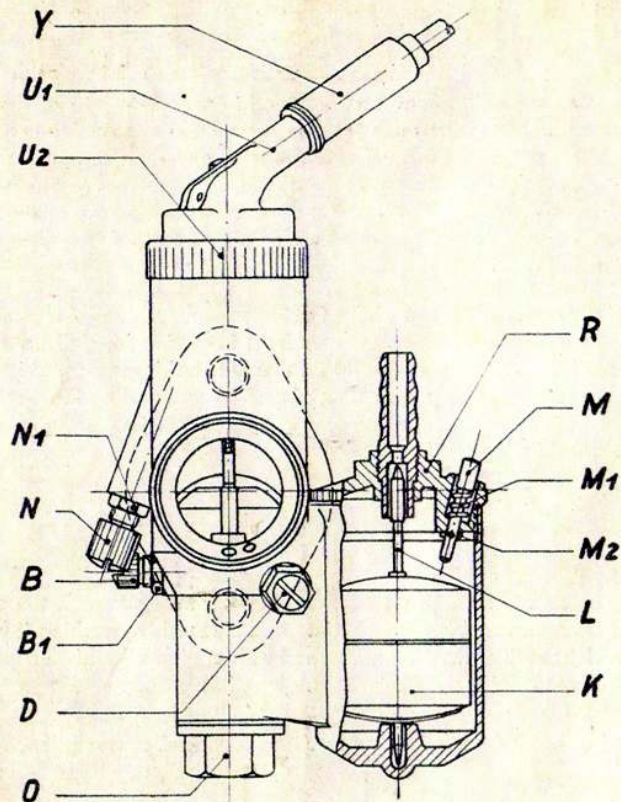

Fig. 18. Carburettor R 71.

- |   |                                 |
|---|---------------------------------|
| Y = Rubber sleeve                             | O = Cap nut with strainer       |
| U <sub>1</sub> = Cover of slide valve housing | R = Cover of float chamber      |
| U <sub>2</sub> = Screw connection             | M = Tickler                     |
| N <sub>1</sub> = Lock nut for N               | M <sub>1</sub> = Tickler spring |
| N = Slide valve stop screw                    | M <sub>2</sub> = Split pin      |
| B = Idling regulating screw                   | L = Float needle                |
| B <sub>1</sub> = Lock nut for B               | K = Float                       |
| D = Safety screw in idling air channel        |                                 |

## Clutch:

The power of the engine is transmitted by the single-plate friction clutch to the change gears. The flywheel, which is fixed on the taper end of the crankshaft by spline and screw, serves as driving member of the clutch.

Six springs (5) arranged in recesses of the flywheel (8) and the pressure plate (4) press the latter against disc (6) which is equipped on both sides with clutch lining and against the fixed end plate (7). By this means the clutch disc (6), which rotates with and is slidingly arranged on the main gear shaft (1), is driven by the flywheel and the rotation of crankshaft (2) is thus transmitted to the main gear shaft (1). The clutch lever on the handle bar operates throw-out lever (9) by means of a Bowden cable, and this lever (9) through the medium of push rod (10) shifts pressure plate (4) away from clutch disc (6), thereby interrupting the power transmission from engine to gears.

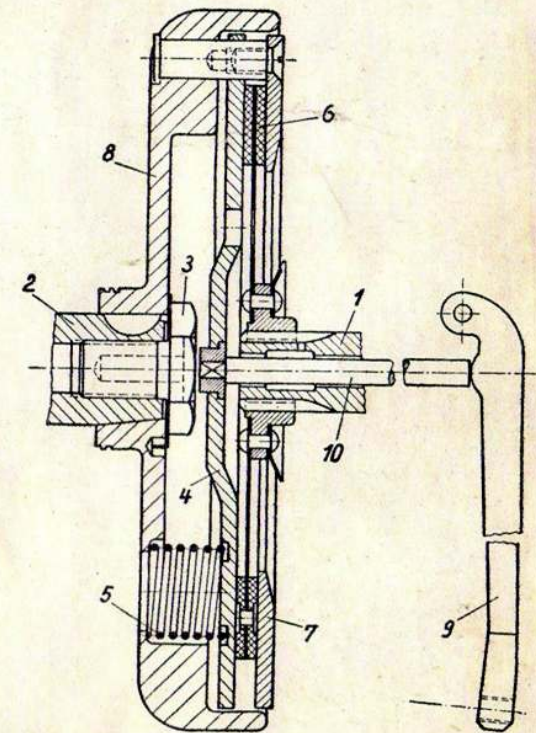

Fig. 19. Clutch

## Transmission gear:

From the clutch the engine power is transmitted through the transmission gear and Cardan shaft to the rear wheel. **Four different gear ratios** permit the full output of the engine to be utilized under all road conditions. The gears remain in permanent mesh. Gear changing is effected by means of a **pedal**, so that both hands can remain on the handle bar, a most important advantage especially on difficult roads. A **hand lever** on the right side of the machine serves to change to neutral direct from any gear position and at the same time indicates the gear in use, since it alters its position with each change of gear.

The **transmission shaft**, which connects the gears to the rear wheel, is fitted at its front end with a **flexible coupling** and further contains a **Cardan or universal joint** to compensate the alterations in the position of the shaft caused by the action of the springs.

**Noiseless spiral bevel gears** transmit the rotation of the shaft to the rear wheel.

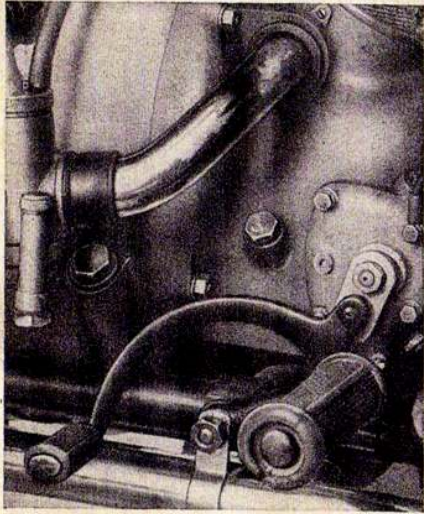

Fig. 20. Gear change pedal.

## Frame:

On the base of experience gained in races and road competitions we now also equip our utility machines with the proved **BMW rear wheel spring suspension**, thereby giving these machines the **greatest possible measure of reliability and comfort** in riding.

### Front wheel fork:

The springing of the front wheel is by means of the well-known **BMW telescopic fork with built-in oil shock absorbers**. The movable wheel carriers (7) are pushed over fixed guide tubes (3) connected to the steering axle. The spring connection between the fixed and movable parts of the fork is by means of a coil spring (2) tightly clamped at both ends. Shock absorbers, consisting of guide tube (8), check valve (6) and narrow passage (4) are further provided. When the fork springs, oil enters the damper chamber (5) and when the fork recoils, this oil is forced to pass through the narrow passage (4), since the check valve has now automatically closed; this results in a very effective

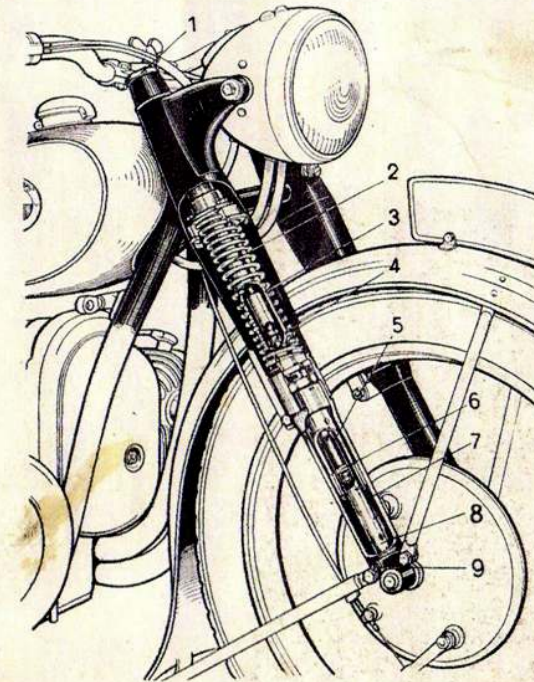

Fig. 21. Front wheel fork.

shock damping action. The oil coming out of the damper chamber (5) flows into the lower part of the fork which serves as oil container.

The entire **shock absorber system can be easily removed without dismantling the fork**, after unscrewing the nut on the lower end of the axle plate and removing the upper hexagonal screw.

Each half of the fork is filled with 80—100 ccm (about  $\frac{1}{3}$  pint) Mobile Oil "Arctic", which should be replaced in very cold weather by a mixture of three parts "Arctic" and one part petroleum (kerosene). The **oil drain screws (6)** are at the lower end of the fork and the **filling-in hole** is closed by the hexagonal screws (1) at the top of the fork. The thumb screw for the **steering damper** is also located in the upper part of the fork; this steering damper can be adjusted to suit road conditions and speed.

**The fork requires no lubrication other than by the oil contained in it.**

Play in the front fork bearings can also be compensated by adjusting the nut situated under the tie plate of the fork halves, after having slackened the damper screw and the large hexagonal nut concentric with the damper screw. For this purpose the nuts arranged at the rear of the top bars near the lower fork cross tube must also be slackened, so that any stress occasioned by adjustment can be relieved.

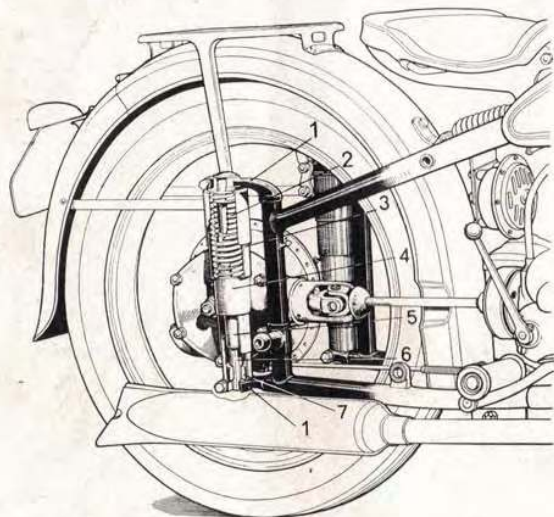

Fig. 22. Spring suspension of rear wheel.

### Spring suspension of the rear wheel:

The springing of the rear wheel is in its main features similar to the suspension of the front wheel and is also of the **telescopic type**.

The stability of the frame is in no wise decreased with this type of springing and alignment as well as correct road holding are ensured under all conditions. All auxiliary stays with their links are eliminated in this suspension system, which forms a harmonious unit of the general frame assembly.

The wheel carrier (4), which is equipped with a long guide sleeve (5), slides on a guide tube (6) clamped on the brackets (1) of the frame. The spring effect is obtained through a coil spring (2) of progressive action fixed at one end to the upper bracket and at the other end to the sliding wheel carrier. Heavy recoils of the spring are taken up by a rubber buffer (7) resting on the lower bracket of the frame. The entire spring system is enclosed dust-proof in telescopic cover tubes (3).

### Maintenance of rear wheel suspension:

Every **1300 miles** lubricate with Mobile Grease No.4. This job can be undertaken with advantage when changing oil at a tanking station.

### Mud guards:

The mud guards are of such shape that they afford ample protection against dirt and water splashed up from the road. The end of the rear mud guard can be tilted up, this greatly facilitating disassembly of the rear wheel.

### Foot rests:

The foot rests are adjustable and their position can be altered to suit the convenience of each individual rider.

### Saddle:

A comfortable **hammock saddle** is fitted, which, in conjunction with the doubly-sprung frame, ensures freedom from fatigue even on the longest runs.

The **spring action of the saddle** can be varied to **suit the weight of the rider** by shifting the spring holder bolt in the long hole of the saddle bracket in an upward direction, this increasing the spring action, or in a downward direction, this diminishing the spring action. Four notches are provided for weights between 130 and 220 lbs.

### Crutch:

A pivoted crutch is provided to prop up the wheel; on the road this crutch is held up by a spring catch. The rear wheel is propped up by depressing the strap on the left side of the crutch and then pulling the machine backwards and upwards.

#### Side car connection:

The frame is provided with suitable lugs, so that a side car can at any time be fitted without difficulty.

#### Tool kit:

All necessary tools are contained in handy arrangement in an easily accessible box sunk into the top of the fuel tank; this box is fitted with a lock and key.

## The R 51 SS Machine

**The R 51 SS is a machine eminently adapted for successfully competing in trophy runs and racing events.**

This machine is in every way similar in build to the R 51 machine, except that the engine and transmission gears have been adapted to the requirements of racing, i. e., the output of the engine has been increased to **28 HP** and the gear ratios have been so chosen that this output can be utilized to the full.

The **telescopic spring suspension** of the rear wheel has proved of especial advantage in this fast machine, the road holding qualities of the driving wheel being greatly augmented and the general road characteristics of the machine being in every way improved.

#### Technical data:

Engine output: 28 HP

Maximum r. p. m.: 5960

Compression ratio: 8 : 1

Gear ratios: 1st = 1 : 2.54

2nd = 1 : 1.88

3rd = 1 : 1.42

top = 1 : 1.19

Rear axle gear ratio: 1 : 3.89

Carburetors: Amal 6/432 S

Main jet: 100 (120)

Needle jet: 267

Needle position: 3

Slide valve: 6/4

**All other dimensions same as R 51.**

It is not possible within the scope of this booklet to enter more fully into racing matters, but the BMW Company is at all times ready to advise gentleman riders in this respect.

## Technical Data

	R 51	R 66	R 61	R 71	
Number of cylinders . . .	2	2	2	2	
Arrangement of cylinders	horizontally opposed				
Cylinder capacity (absolute) . . . . .	30	36 <sup>1</sup> / <sub>2</sub>	36 <sup>1</sup> / <sub>2</sub>	45 <sup>1</sup> / <sub>2</sub>	cub in.
Cylinder bore . . . . .	2.70	2.75	2.75	3.10	in.
Stroke . . . . .	2.70	3.10	3.10	3.10	in.
Compression ratio . . . . .	1 : 6.7	1 : 6.8	1 : 6	1 : 5.5	
R. p. m. at 37 m. p. h. . . . .	2500	2350	2500	2350	Solo machine
	3000	2850	3000	2500	Side car machine
R. p. m., maximum . . . . .	5800	5700	4800	4900	
Continuous output . . . . .	24	30	18	22	b. h. p.
Valves . . . . .	overhead		side		
Number of valves . . . . .	2	2	2	2	per cylinder
Intake opens . . . . .	.390	.445	.440	.440	in. before u. d. c.
Intake closes . . . . .	.940	1.060	1.080	1.080	in. after l. d. c.
Exhaust opens . . . . .	.940	1.060	1.080	1.080	in. before l. d. c.
Exhaust closes . . . . .	.390	.445	.440	.440	in. after u. d. c.
Advance ignition . . . . .	.475	.495	.237	.237	in. before u. d. c.
Carburettors . . . . .	Amal 5/423	Amal 6/420 S	Amal M75/426S	Graetzin G 24	
Main jet . . . . .	85	100	80	95 L.f. 35	
Needle jet . . . . .	267	267	267	43	
Needle position . . . . .	3	3	2	2	
Slide valve . . . . .	5/5	6/6	5/4	—	
Fuel consumption, approx. . . . .	70	63	70-80	63	m. p. g.
Fuel tank capacity . . . . .	3	3	3	3	gals.
Oil consumption . . . . .	.3 to .5	.3 to .5	.3 to .5	.3 to .5	pints per 100 m
Oil tank capacity . . . . .	3 <sup>1</sup> / <sub>2</sub>	3 <sup>1</sup> / <sub>2</sub>	3 <sup>1</sup> / <sub>2</sub>	3 <sup>1</sup> / <sub>2</sub>	pints
Gear ratios: 1st . . . . .	1 : 3.6	1 : 3.6	1 : 3.6	1 : 3.6	
2nd . . . . .	1 : 2.28	1 : 2.28	1 : 2.28	1 : 2.28	
3rd . . . . .	1 : 1.7	1 : 1.7	1 : 1.7	1 : 1.7	
top . . . . .	1 : 1.3	1 : 1.3	1 : 1.3	1 : 1.3	
Rear axle . . . . .	1 : 3.89	1 : 3.6	1 : 3.89	1 : 3.6	
Side car gear ratio . . . . .	1 : 4.62	1 : 4.38	1 : 4.62	1 : 3.89	
Maximum speed . . . . .	84-87	87-90	69-72	75-78	m. p. h.
With side car gear . . . . .	65-69	72-75	59-63	63-65	m. p. h.
Wheel base . . . . .	55	55	55	55	in.
Height of saddle . . . . .	28 <sup>1</sup> / <sub>2</sub>	28 <sup>1</sup> / <sub>2</sub>	28 <sup>1</sup> / <sub>2</sub>	28 <sup>1</sup> / <sub>2</sub>	in.
Overall length . . . . .	84	84	84	84	in.
Overall width . . . . .	32	32	32	32	in.
Overall height . . . . .	38	38	38	38	in.
Weight, ready for road . . . . .	400	410	405	410	lbs.
Admissible total weight . . . . .	1100	1100	1100	1100	lbs.
Tyres . . . . .	3.5 x 19	3.5 x 19	3.5 x 19	3.5 x 19	

## INDEX

Advanced ignition . . . . .	5
Air filter . . . . .	31
Automatic regulation of dynamo . . . . .	22
<b>Battery . . . . .</b>	<b>20</b>
Brakes . . . . .	22
Brakes, adjustment . . . . .	23
Braking when running downhill . . . . .	23
Brushes of dynamo . . . . .	22
<b>Camshaft drive . . . . .</b>	<b>27, 28</b>
Carburettor R 51/61/66, cleaning . . . . .	15
Carburettor R 71, cleaning . . . . .	15
Carburettors, description . . . . .	29
Carburettor R 71, description . . . . .	32
Cardan joint . . . . .	34
Cardan shaft . . . . .	34
Care of machine . . . . .	17
Castor oil . . . . .	18
Chain drive of camshaft . . . . .	27
Changing tyres . . . . .	12
Check valve in fork . . . . .	35
Cleaning the carburettors . . . . .	15
Cleaning the engine . . . . .	24
Clutch . . . . .	24, 33
Clutch, letting in . . . . .	8, 24
Clutch lever . . . . .	5, 33
Commutator of dynamo . . . . .	22
Contact breaker . . . . .	21
Control lamp . . . . .	5, 7
Controls . . . . .	5
Crankcase . . . . .	26
Crankcase evacuation . . . . .	27, 28
Crankshaft . . . . .	26
Crutch . . . . .	37
Cylinders . . . . .	26
Cylinder head R 66 (R 55) . . . . .	18
<b>Declutching . . . . .</b>	<b>8, 9</b>
Dimming switch . . . . .	5
Disassembling the front wheel . . . . .	12

Disassembling the rear wheel . . . . .	13
Distance light . . . . .	5
Distributor . . . . .	21
Drive of camshaft . . . . .	27, 28
Drive of dynamo . . . . .	27, 28
Dynamo . . . . .	22
<b>Engine, description and operation . . . . .</b>	<b>25</b>
Engine lubrication . . . . .	29
Engine, maintenance . . . . .	18
Engine of R 71, view . . . . .	17
Evacuation of crankcase . . . . .	27, 28
<b>Flexible coupling of transmission shaft . . . . .</b>	<b>34</b>
Foot brake lever . . . . .	5
Foot rests . . . . .	37
Fork disassembly . . . . .	36
Frame . . . . .	35
Front wheel fork . . . . .	35
Fuel . . . . .	7
Fuel cock . . . . .	7
Fuel consumption . . . . .	40
Fuel filling hole . . . . .	5
<b>Gas control . . . . .</b>	<b>5</b>
Gas slide valve . . . . .	29
Gear control . . . . .	5
Gear pump . . . . .	29
Gear ratios . . . . .	40
Grip gas control . . . . .	5
<b>Hand brake lever . . . . .</b>	<b>5</b>
Hand gear lever . . . . .	5, 9
Heat coefficient of sparking plugs . . . . .	20
<b>Ignition adjustment . . . . .</b>	<b>8, 9</b>
Ignition coil . . . . .	21
Ignition key . . . . .	5
Ignition lever . . . . .	5
Ignition system, care of . . . . .	20
Ignition system, view . . . . .	20
<b>Kick starter . . . . .</b>	<b>5</b>
Kick starter, operation . . . . .	7

Letting in the clutch . . . . .	8, 24
Lubricants . . . . .	11, 45
Lubrication chart . . . . .	45
Lubrication of engine . . . . .	29
Lubrication, general . . . . .	10, 17
<b>Maintenance . . . . .</b>	<b>18</b>
Maximum speeds . . . . .	8, 9, 10, 11, 40
Mounting the tyre . . . . .	14
Mud guards . . . . .	37
<b>Oil consumption . . . . .</b>	<b>40</b>
Oil gauge rod . . . . .	7, 17
Oil level . . . . .	7, 17
Oil pump . . . . .	29
<b>Pedal brake . . . . .</b>	<b>5</b>
Pedal gear control . . . . .	5
Pistons . . . . .	26
Push button for horn . . . . .	5
<b>R 51 SS machine . . . . .</b>	<b>39</b>
Racing . . . . .	18, 39
Racing machine R 51 SS . . . . .	39
Racing oil . . . . .	18
Rear wheel brake . . . . .	22
Rear wheel, disassembly . . . . .	13
Rear wheel spring suspension . . . . .	35, 36
Removing the tyre . . . . .	14
Repairing the inner tube . . . . .	14
Retarded ignition . . . . .	5
Rotary grip gas control . . . . .	5
Running-in period . . . . .	10
Running instructions in short . . . . .	6, 7
<b>Saddle . . . . .</b>	<b>37</b>
Sealed stop on carburettor . . . . .	10
Shock absorbers . . . . .	35, 36
Shock absorber fluid . . . . .	36
Side car connection . . . . .	38
Sparking plugs . . . . .	20

Spring suspension of rear wheel . . . . .	35, 36
Spur gear drive of camshaft . . . . .	28
Speedometer . . . . .	5
Starting . . . . .	6
Steering damper . . . . .	5, 36
Stop light . . . . .	5
Stopping . . . . .	8

Technical data of the R 51/66/61/71 machines . . . . .	40
Technical data of the R 51 SS machine . . . . .	39
Telescopic fork . . . . .	35
Tickler . . . . .	7
Tightening up camshaft drive chain . . . . .	28
Tool kit . . . . .	38
Top lubricant . . . . .	7
Transmission gear . . . . .	34
Transmission shaft . . . . .	34
Tyres . . . . .	6, 14, 40
Tyre changing . . . . .	12
Tyre dimensions . . . . .	40
Tyre pressure . . . . .	7, 14

Universal joint . . . . .	34
---------------------------	----

Valve clearance adjustment R 51/66 . . . . .	18
Valve clearance adjustment R 61/71 . . . . .	19
Valves, description and operation . . . . .	26

Weight of machine . . . . .	40
-----------------------------	----

## Lubrication Chart

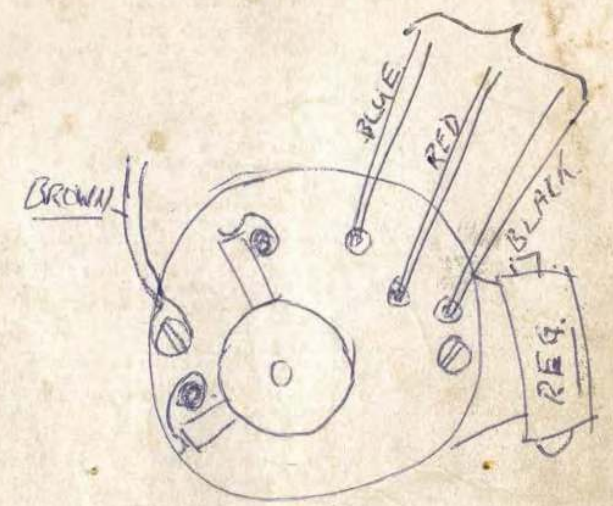



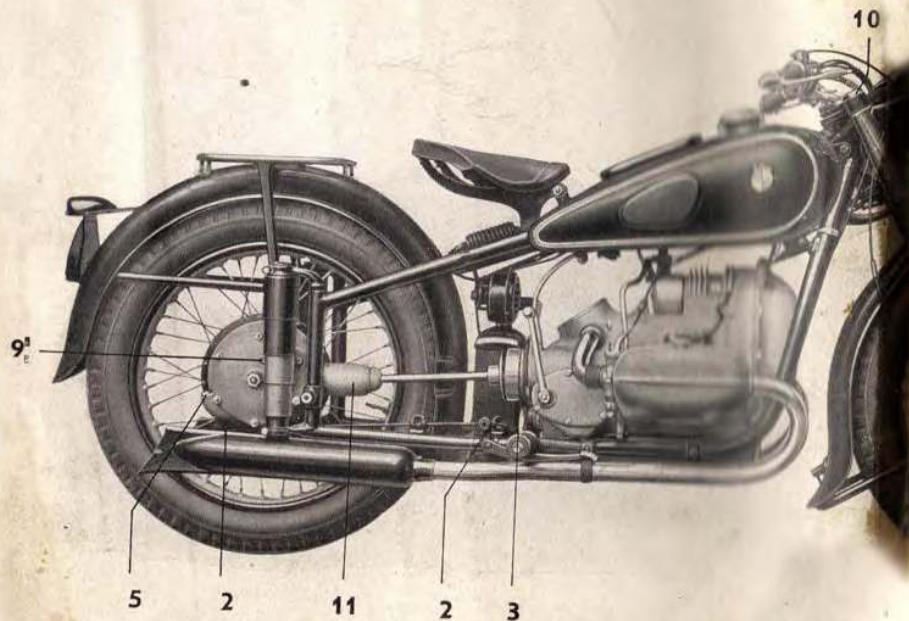
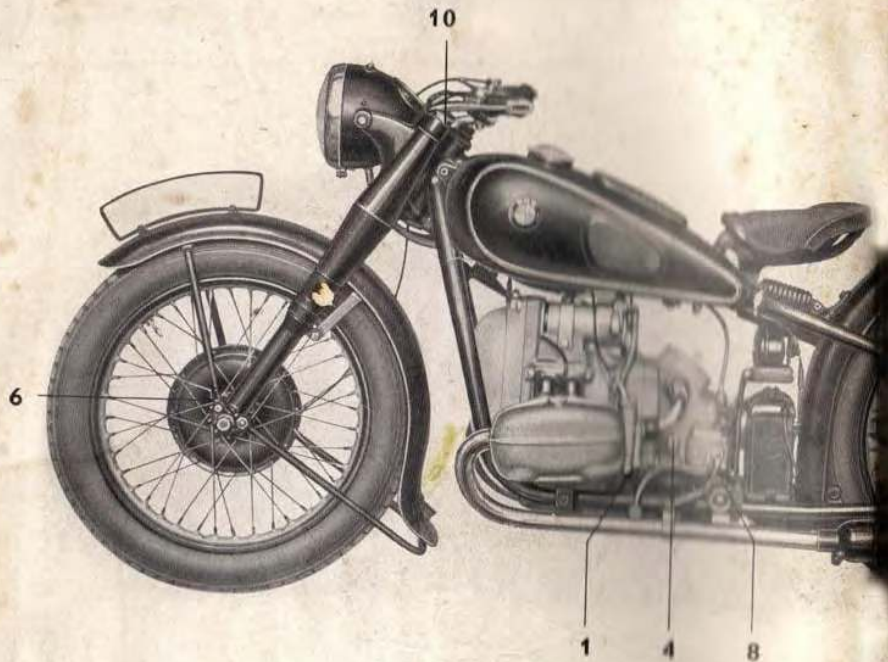

## Lubrication Chart

- 1 Engine:**  
Check oil level every **250 miles**.  
Push gauge rod in, do not screw in.  
Drain off oil every **1300 miles** and fill in fresh oil.  
Summer: **Mobile Oil BB**.  
Winter: **Mobile Oil Arctic**.
- 2 Brake joints:**  
Lubricate every **250 miles** with **engine oil**.
- 3 Clutch lever:**  
Lubricate every **250 miles** with **engine oil**.
- 4 Transmission gears:**  
Check oil level every **650 miles**.  
Oil should reach up to lower thread of filling-in hole.  
Drain off every **10000 miles** and fill in fresh oil.  
Summer: **Mobile Oil BB**.  
Winter: **Mobile Oil BB** (in very cold weather **Arctic**).
- 5 Rear axle casing:**  
Check oil level every **650 miles**.  
Oil should reach to lower thread of filling-in hole.  
Drain off every **10000 miles** and fill in fresh oil **Mobile Oil EP**.
- 6 Front wheel hub:**  
Fill with grease gun every **10000 miles** **Mobile Grease No. 4**.
- 7 Rear wheel hub:**  
Fill with grease gun every **10000 miles** **Mobile Grease No. 4**.
- 8 Gear change pedal:**  
Fill with grease gun every **1300 miles** **Mobile Grease No. 4**.
- 9 Rear wheel spring suspension:**  
Fill with grease gun every **1300 miles** **Mobile Grease No. 4**.
- 10 Front wheel fork:**  
Fill in about **1/5 pint Arctic** occasionally.
- 11 Universal joint:**  
Fill with grease gun every **10000 miles**.  
Lubrication nipple is under bell-shaped guard (left-hand thread). **Mobile Grease No. 4**.

	Check	Lubricate
Every 250 miles	1	2, 3
Every 650 miles	4, 5	
Every 1300 miles		1, 8, 9
Every 10000 miles		4, 5, 6, 7, 11

**It is recommended to carry out all lubrication jobs at a tank station, because all requisites and lubricants are available there.**  
Instead of the above, other good lubricants of corresponding grade can of course be employed.

